

SafetyCast™ 300 Virtual Walkway Projector Datasheet



Overview:

The SafetyCast™ 300 Virtual Walkway Projector are the ideal way to display bright floor and wall safety signs in locations where there is high traffic, potential for a hazard, or uneven floors. The SafetyCast™ 300 Virtual Walkway Projector uses an image lens and a high-output LED bulb to project a clear sign at distances of up to 70 m (230'). The SafetyCast™ 300 Virtual Walkway Projector works well in almost all lighting conditions and is easy to mount and adjust. Once installed, there's virtually no maintenance, and you won't need to worry about replacing damaged signs on your floors or walls.

Key Features:

- High-contrast image projection
- Powerful close-range and long-range projection
- Interchangeable image lenses
- Minimal maintenance – low total cost of ownership
- A large variety of safety signage

Specifications:

Lamp Details

Type of Light Source:	High Performance LED
Light Source Life (MTTF):	30,000 hours at 25°C/77°F

Optical

Light Colour Temperature:	6,000 K
Luminous Flux:	30,000 lm
Projection Distance:	Up to 230 ft (70 m) in dark ambient lighting
Beam Projection Lens Angles:	Medium: f=115mm / 25°; Wide: f=90mm / 35°; and Ultra Wide: f=56mm / 45°

Temperature Range:	2°C to 50°C (35 to 120 °F)
Storage Temperature Range:	-10 to 50°C (15 to 120 °F)
Relative humidity:	5% to 80% noncondensing
IP Rating:	IP55
Projector Power:	300W
Power Supply (included):	100-240 VAC nominal, 50/60 Hz, 2.5A, 300W

Standard Warranty:	12 months
---------------------------	-----------

Smart Triggered Projection:	Projection flashing using either Motion Sensors or Break of Beam sensors
------------------------------------	--

SafetyCast™ 300 Virtual Walkway Projector

Product Series

SKU Guide - HSV 3 H 059 X

Power

3 = 300W

Image Type

Projection	300W	Projection	300W
	061		059
	058		060
	102		CUS

Bilingual version English/French

Lens Angle

H = Medium Angle (25°)

I = Wide Angle (35°)

J = Extra Wide Angle (45°)

Type

X = Fan Cooled

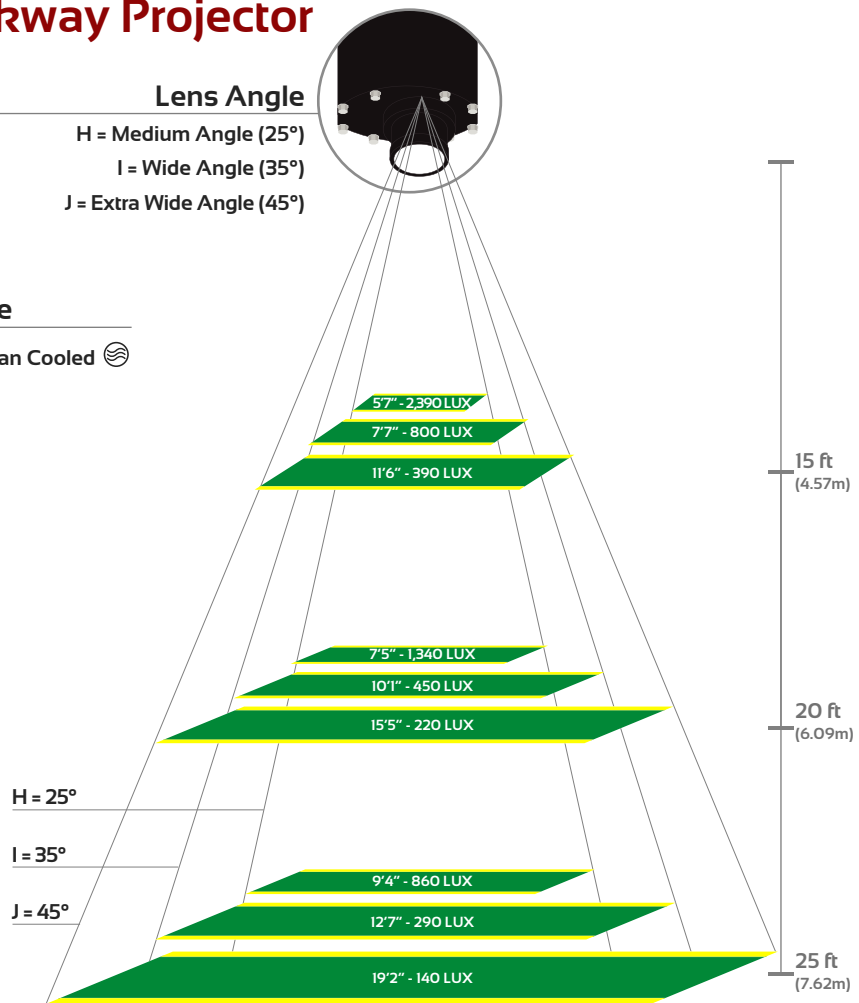

Accessories:

The most popular accessories for model HSV3_ _ _ X are shown below. For additional details regarding these or other accessories please see our website or contact us directly.

Product SKU	Description	Product SKU	Description	Product SKU	Description
Smart Trigger Kits / Sensors		Sensors / Cables / Mounting Hardware		Lenses	
STB300XXX	Smart Trigger Basic Control Kit (Single Input and Output)	SENPBKXXX	Momentary Push Button Sensor Kit	AOO30025T	Lens Only - 300W 25° Fan Cooled
HSCCTRLAX	Smart Trigger Pro Control Kit (Multiple Inputs and/or Outputs)	STBSIGC2X	Signal Cable Extension (2m)	AOO30035T	Lens Only - 300W 35° Fan Cooled
HSCRLY3PX	Signal Relay Box for Multiple Projectors	STBSIGC5X	Signal Cable Extension (5m)	AOO30045T	Lens Only - 300W 45° Fan Cooled
SENIMKXXX	Indoor Motion Sensor Kit	STBSENC2X	Sensor Cable Extension (2m)	AOG_ _ _ XY	Image Template Only
SENMADPTX	4 Motion Sensor Input Adapter	STBSENC5X	Sensor Cable Extension (5m)		
SENB03KXX	Retroreflective Beam Break Sensor Kit (3m range)	ABM088CXX	No Drill Magnetic Mounts		
SENB30KXX	Retroreflective Beam Break Sensor Kit (30m range)				

SafetyCast™ 300 Virtual Walkway Projector

Projector dimensions:

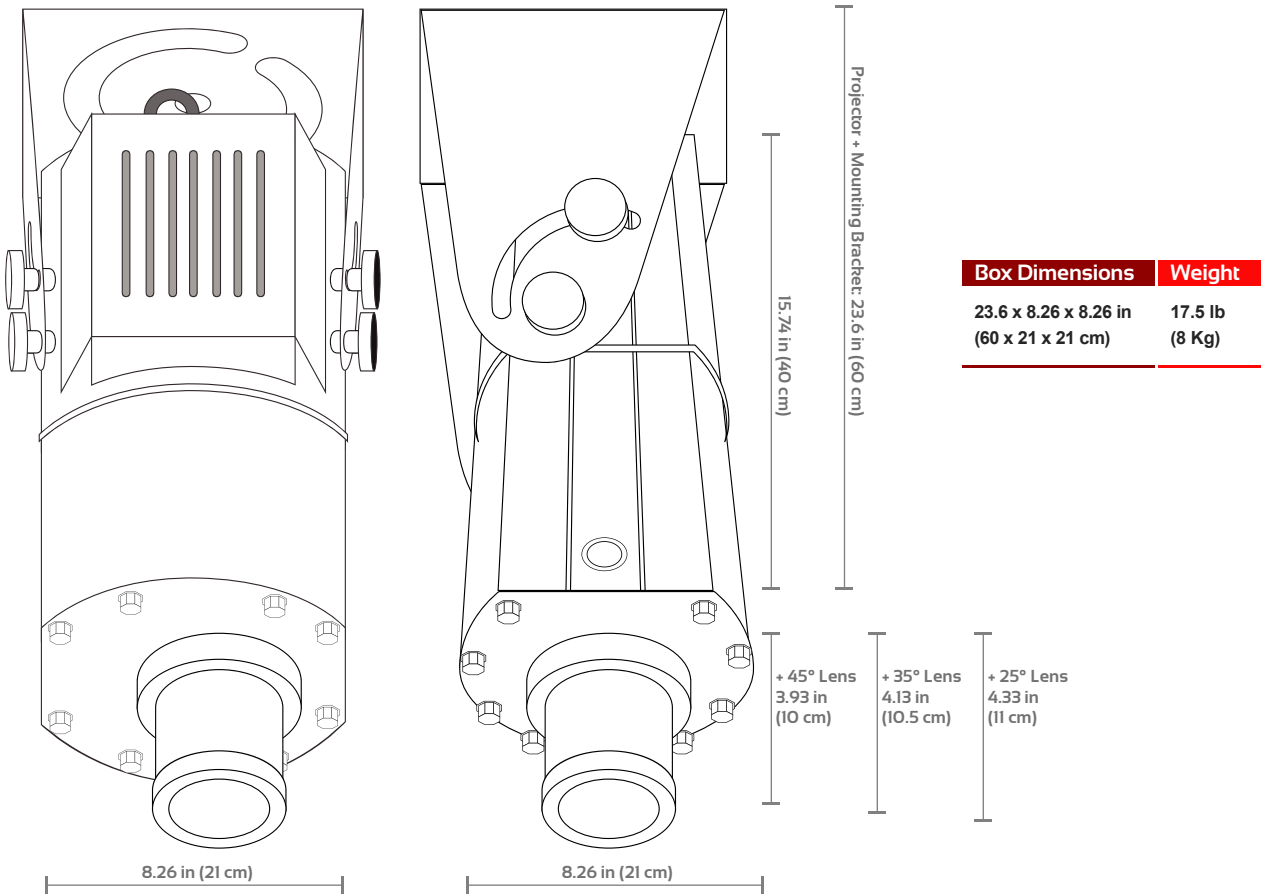

Power Supply dimensions:

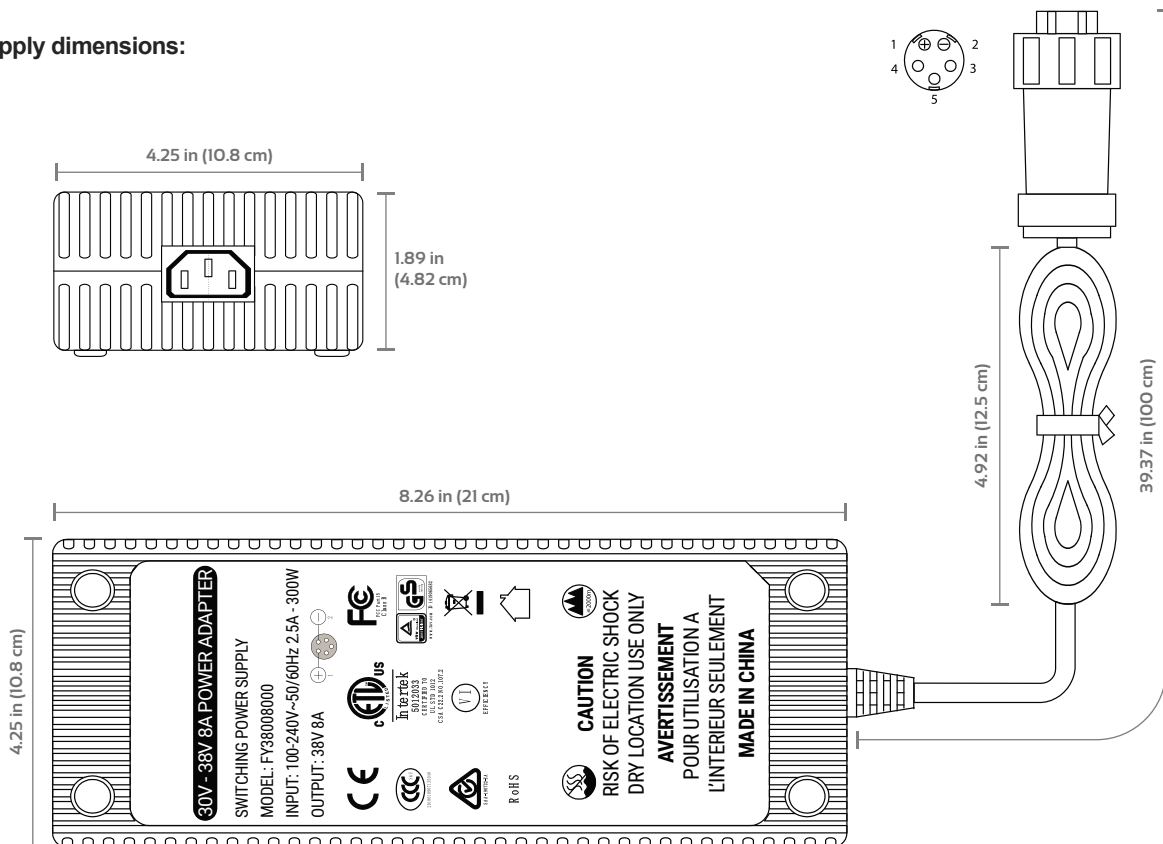



www.proxsecur.ca

For more information, please contact:

Solutions Prox-Secur

5782 boul. Thimens, Saint-Laurent, Qc, Canada, H4R 2K9

Tel. (514) 333-0077 Fax (514) 333-0078

info@proxsecur.ca

E&OE: Data included in this sheet may be subject to change without notice.
Please confirm critical specifications with our staff prior to ordering.